

## Energy and Exergy Analysis of a Hybrid Air-Conditioning System

Arif ÖZBEK\*<sup>1</sup>

<sup>1</sup>Çukurova University, Ceyhan Engineering Faculty, Department of Mechanical Engineering, Adana

Geliş tarihi: 03.07.2018

Kabul tarihi: 15.10.2018

### Abstract

In summer months, an increase in electricity demand with the use of air conditioning systems requires the more economical use of energy. Energy saving can be achieved by using the same work with less energy or by developing the conventional methods. In this study, energy and exergy analysis of a solar assisted hybrid air-conditioning system operating in cooling mode is carried out analytically. Performance analysis was then performed comparing with the situation in which no solar energy support was used. Results indicate that solar panel usage improves system COP by 16% and exergy destruction rate increases through the condenser and compressor, but decreases through the evaporator and capillary tube. Furthermore, total exergy destruction and overall exergy efficiency values of the system increase by using the panel.

**Keywords:** Hybrid air-conditioning, Energy, Exergy

### Hibrit bir İklimlendirme Sisteminin Enerji ve Ekserji Analizi

#### Öz

Yaz aylarında iklimlendirme sistemlerinin kullanılmasıyla elektrik ihtiyacındaki artış enerjinin daha tasarruflu kullanımını gerektirmektedir. Enerji tasarrufu aynı işi daha az enerji kullanarak veya bilinen klasik yöntemleri geliştirerek elde edilebilir. Bu çalışmada, soğutma modunda çalışan güneş enerjisi destekli bir hibrit iklimlendirme sisteminin analitik olarak enerji ve ekserji analizleri yapılmış; güneş enerjisi desteği kullanılmadığı durum ile kıyaslanarak performans analizleri gerçekleştirilmiştir. Sonuçlar panel kullanımının sistem performansını %16 artırdığını; kondenser ve kompresörde ekserji yok oluş hızı artarken evaporatör ve kılcal boruda ise azaldığını göstermiştir. Ayrıca panel kullanımı toplam ekserji yok oluşunu ve toplam ekserji verimliliğini de artırmıştır.

**Anahtar Kelimeler:** Hibrit iklimlendirme, Enerji, Ekserji

---

\*Sorumlu yazar (Corresponding author): Arif ÖZBEK, arozbek@cu.edu.tr

## 1. INTRODUCTION

Since the beginning of the 21<sup>st</sup> century, the average global temperature has increased by 0.6 °C (UN Intergovernmental Panel on Climate Change). In addition, it is stated that the average temperature will increase by 1.4-4.5 °C until 2100 according to the 'Climate Change Panel' edited in 2001. When global warming has reached such a serious level, many efforts are being made to prevent or slow it down [1,2].

Solar energy has come to the forefront when compared to other renewable energies because of easy implementation and lower installation costs. The biggest application areas of solar energy have been water and ambient heating. However, during periods when the ambient heating is most needed, the problem is that the sunlight is low and not being used efficiently. In summer periods when solar radiation is the most intense, there is no need for ambient heating, but cooling is required [2].

Split air conditioning systems are ideal energy efficient solutions for heating and cooling of houses and workplaces. Split air conditioners consist of an inner unit that exchanges heat with inside air and outdoor unit that exchanges heat with the outdoor environment. The noise levels of this type of the systems are low. Ceiling-type split air conditioners, operating efficiency and aesthetic is more preferable than the other individual air conditioning systems. It provides excellent air filtration with improved filtration [3-5].

There are many studies about air conditioning systems with or without the assistance of solar energy. Energy and exergy analysis of a ceiling-type residential air conditioning system operating under different climatic conditions investigated for the provinces within the different geographic regions of Turkey by Ozbek [6]. He tried to reveal the exergy destructions in this system of buildings located in different climatic zones of Turkey. He also applied energy and exergy analysis to a ceiling-type air conditioning system operating with various refrigerants. He examined that which refrigerant is a good alternative for this type of systems by

considering the Global Warming Potential values of the refrigerants [7].

Vakiloroaya et al. [8] improved an air-conditioning system combined with a vacuum solar collector in order to benefit from solar energy. A mathematical model of the system components was also developed and validated against experimental results. Paradeshi L. et al. [9] studied theoretically and experimentally direct expansion solar assisted heat pump system under a different metrological condition in India. Their system included a flat-plate solar collector of 2 m<sup>2</sup> total area, acting as an evaporator with refrigerant R22. Based on the experiment and developed system simulation model, the thermal performance of direct expansion solar assisted heat pump system was studied under the metrological condition of India.

Simsek and Karacayli [10] investigated the performance analysis of a ceiling type split air conditioning system in cooling mode when solar panel was used and not used, and then they compared the effect of panel usage on the performance of the cooling system.

In this study, energy and exergy analysis of a solar assisted hybrid air-conditioning system (with panel) operating in cooling mode is carried out analytically under atmospheric conditions of Adana province. Performance analysis was then performed comparing with the situation in which no solar energy support was used (without panel).

## 2. MATERIAL and METHOD

### 2.1. System Description

The refrigerant is compressed to a solar panel as a superheated vapor at high pressure and temperature by the compressor (Figure 1). In the panel, the temperature of the refrigerant is increased and its pressure is balanced. The refrigerant is then sent from panel to condenser (the outer unit). The refrigerant condenses inside the condenser rejects heat to the outside and pressure of the refrigerant is reduced in a capillary tube. The refrigerant is sent from the capillary tube to the evaporator. When the

refrigerant vaporized, the refrigerant absorbs heat from surrounding and transferred to heat from ambient to refrigerant. And it absorbed by the compressor at the exit of the evaporator. After that heat transfer occurs between compressor and refrigerant. Refrigerant became superheat vapor

phase and return the cylinder of the compressor. So this cycle is completed. Figure 3 represents schematic drawing of both cycles (with the panel and without panel) on the lnP-h diagram for Adana province.

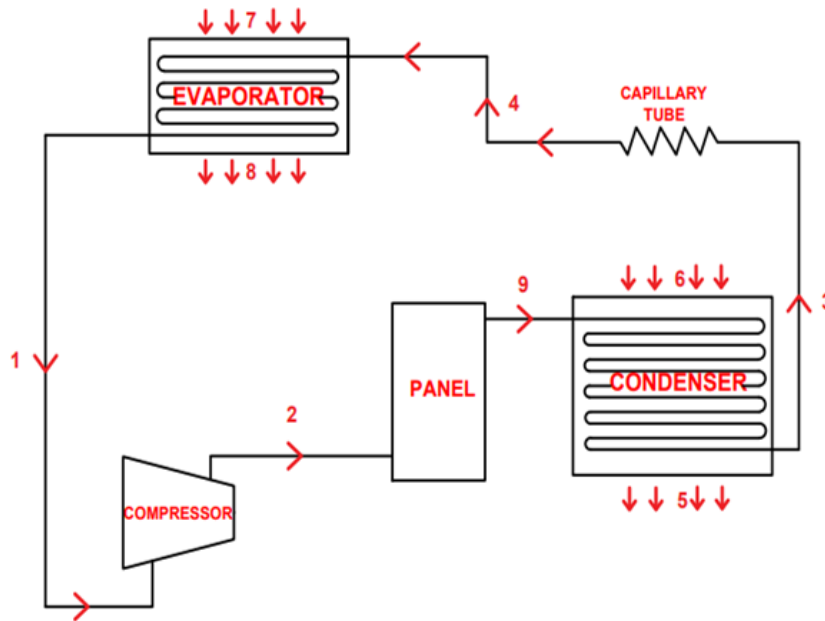

Figure 1. Flow diagram of the with the panel system

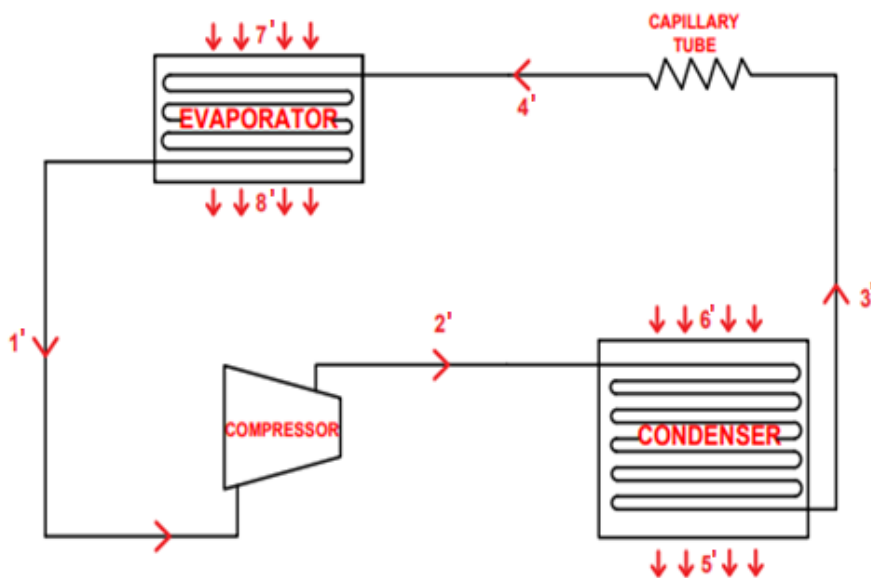

Figure 2. Flow diagram of the without panel system

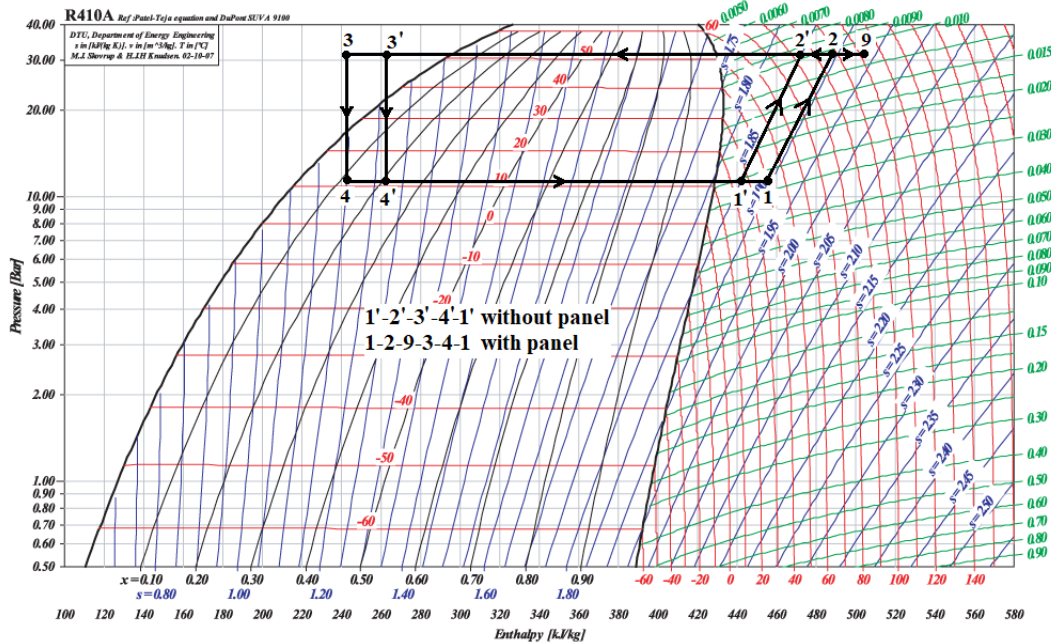

Figure 3. LnP-h diagram of the both system

The hybrid air-conditioning system which performs a cycle, the energy that is transferred to the outdoor during the return of the refrigerant to the initial conditions is obtained by consuming it from the inside of the phase conversion. In with panel system, first of all, compressor send to the refrigerant to the solar panel (state 2) and there will be heat transfer between refrigerant and panel in this section. With this energy transfer provided, the refrigerant enters the condenser with higher energy and temperature but same pressure (State 9), so the refrigerant transfers more heat to the outer atmosphere because the temperature difference with surroundings will be more. While returning to the initial conditions, more heat is transferred from the inner side environment to the refrigerant, thereby improving the performance of the system [10].

## 2.2. Analysis of the Vapor Compression Refrigeration Cycle

In order to compute heat transfer rates from condenser and evaporator, COP, exergy destruction and exergy efficiency of the refrigeration system and its components; mass, energy, and exergy balance equations can be applied [7].

The general mass balance equation;

$$\sum \dot{m}_{in} = \sum \dot{m}_{out} \quad (1)$$

Energy balance;

$$\dot{E}_{in} = \dot{E}_{out} \quad (2)$$

The energy balance for a general steady-flow system;

$$\dot{Q}_{in} + \dot{W}_{in} + \sum_{in} \dot{m} \left( h + \frac{v^2}{2} + gz \right) = \dot{Q}_{out} + \dot{W}_{out} + \sum_{out} \dot{m} \left( h + \frac{v^2}{2} + gz \right) \quad (3)$$

The general exergy balance;

$$\dot{E}x_{in} - \dot{E}x_{out} = \dot{E}x_{dest} \quad (4)$$

The general exergy balance equation is:

$$\dot{E}_{heat} - \dot{E}_{work} + \dot{E}_{mass,in} - \dot{E}_{mass,out} = \dot{E}x_{dest} \quad (5)$$

The rate of the general exergy balance [6]:

$$\sum \left(1 - \frac{T_0}{T_k}\right) * \dot{Q}_k - \dot{W} + \sum \dot{m}_{in} \Psi_{in} - \sum \dot{m}_{out} \Psi_{out} = \dot{E}x_{dest} \quad (6)$$

where  $T_k$  is the temperature at which the heat transfer crosses the system boundary,  $\dot{W}$  is the work rate and  $\Psi$  the flow (specific) exergy and the subscript zero indicates properties at the reference (dead) state of  $P_0$  and  $T_0$ . The reference temperature and pressure values used in calculations are taken to be 36.8 °C and 101.3 kPa for Adana province [6].

The specific flow exergy of refrigerant or air:

$$\Psi_{ref,a} = (h - h_0) - T_0(s - s_0) \quad (7)$$

The exergy rate:

$$\dot{E}x = \dot{m} * \Psi \quad (8)$$

The exergy efficiency of different steady flow devices;

$$\eta = \frac{\dot{E}x_{out}}{\dot{E}x_{in}} \quad (9)$$

The energy-based efficiency measure of the refrigeration unit;

$$COP_R = \frac{\dot{Q}_{evap}}{\dot{W}_{comp,act}} \quad (10)$$

Reversible power is the minimum power needed to be supplied to the compressor and there is no difference between useful work ( $\dot{W}_{comp,act}$ ) and exergy destruction (irreversibility);

$$\dot{W}_{comp,rev} = \dot{W}_{comp,act} - \dot{E}x_{dest} = \dot{E}_{out,comp} - \dot{E}_{in,comp} \quad (11)$$

### 2.3. Energy and Exergy Analysis for the System Components

Energy and exergy analyses have been applied to both cycles in Figures 1 and 2. The hybrid air-conditioning system operates with Refrigerant 410A, and the condensation temperature is taken as 15 °C above atmospheric temperature. The evaporation temperature is assumed to be 15 °C below the indoor temperature. The panel

temperature is assumed to be 15 °C above the temperature of the compressor outlet. [6].

Assumptions below are performed during the calculations:

- Negligible potential and kinetic energy effects,
- Steady-state operation for all components of the system,
- The power consumptions of the condenser and evaporator can be neglected,
- Since connection lengths between the components are short; heat transfer and refrigerant pressure drops in the connecting tubing may be ignored,
- The temperatures of the refrigerant at state 1 and 1' ( $T_1$  and  $T_{1'}$ ), shown in Figure 1 and 2, are assumed to be 10 °C higher than the evaporation temperature of the refrigerant. The temperatures of the refrigerant at state 3 and 3' ( $T_3$  and  $T_{3'}$ ), is assumed to be 10 °C below the condensation temperature of the refrigerant. Thus, the refrigerant leaves the condenser as a compressed liquid and enters the compressor as a superheated vapor.

Refrigerant 410A is used as the working fluid for both systems. There are four main elements: the compressor, condenser, capillary tube and evaporator in without panel system. The system with panel has a panel located at the compressor exit to increase refrigerant temperature. The refrigerant passes through this panel to absorb a maximum amount of solar energy.

Mass, energy balance, exergy destruction and exergy efficiency obtained from the exergy balance equation for each system components may be represented as follows [6-7]:

#### Compressor:

$$\dot{m}_1 = \dot{m}_2 = \dot{m}_{ref} \quad (12a)$$

$$\dot{W}_{comp,act} = \dot{m}_{ref} * (h_2 - h_1) \quad (12b)$$

$$\Psi_1 = (h_1 - h_0) - T_0(s_1 - s_0) \quad (12c)$$

$$\Psi_2 = (h_2 - h_0) - T_0(s_2 - s_0) \quad (12d)$$

$$\dot{E}x_1 = \dot{m}_{ref} \times \Psi_1 \quad (12e) \quad \dot{E}x_{cap.} = \dot{m}_{ref} \times (\Psi_3 - \Psi_4) \quad (15c)$$

$$\dot{E}x_2 = \dot{m}_{ref} \times \Psi_2 \quad (12f) \quad \eta_{cap} = \frac{\Psi_4}{\Psi_3} \quad (15d)$$

$$\dot{E}x_{dest.comp} = \dot{m}_{ref} \times (\Psi_1 - \Psi_2) + \dot{W}_{comp.act} \quad (12g)$$

$$\eta_{comp} = \frac{\dot{E}x_2 - \dot{E}x_1}{\dot{W}_{comp.act}} \quad (12h)$$

**Panel:**

$$\dot{m}_9 = \dot{m}_{ref} \quad (13a)$$

$$\Psi_9 = (h_9 - h_0) - T_0(s_9 - s_0) \quad (13b)$$

$$\dot{E}x_9 = \dot{m}_{ref} \times \Psi_9 \quad (13c)$$

$$\dot{E}x_{pan.} = \dot{m}_{ref} \times (\Psi_9 - \Psi_2) \quad (13d)$$

**Condenser:**

$$\dot{m}_3 = \dot{m}_9 = \dot{m}_{ref} \quad (14a)$$

$$\dot{m}_5 = \dot{m}_6 = \dot{m}_{air} \quad (14b)$$

$$\dot{Q}_{cond} = \dot{m}_{ref} \times (h_9 - h_3) = \dot{m}_{air} \times \dot{c}_{p.air} \times (T_6 - T_5) \quad (14c)$$

$$\Psi_3 = (h_3 - h_0) - T_0(s_3 - s_0) \quad (14d)$$

$$\Psi_5 = (h_5 - h_0) - T_0(s_5 - s_0) \quad (14e)$$

$$\Psi_6 = (h_6 - h_0) - T_0(s_6 - s_0) \quad (14f)$$

$$\dot{E}x_5 = \dot{m}_{ref} \times \Psi_5 \quad (14g)$$

$$\dot{E}x_6 = \dot{m}_{ref} \times \Psi_6 \quad (14h)$$

$$\dot{E}x_{dest.con} = \dot{m}_{ref} \times (\Psi_9 - \Psi_3) + \dot{m}_{air} \times (\Psi_6 - \Psi_5) \quad (14i)$$

$$\eta_{comp} = \frac{\dot{m}_{air} \times (\Psi_6 - \Psi_5)}{\dot{m}_{ref} \times (\Psi_9 - \Psi_3)} \quad (14j)$$

**Capillary Tube:**

$$\dot{m}_3 = \dot{m}_4 = \dot{m}_{ref} \quad (15a)$$

$$\Psi_4 = (h_4 - h_0) - T_0(s_4 - s_0) \quad (15b)$$

**Evaporator:**

$$\dot{m}_1 = \dot{m}_4 = \dot{m}_{ref} \quad (16a)$$

$$\dot{m}_7 = \dot{m}_8 = \dot{m}_{air} \quad (16b)$$

$$\dot{Q}_{evap} = \dot{m}_{ref} \times (h_1 - h_4) = \dot{m}_{air} \times \dot{c}_{p.air} \times (T_7 - T_8) \quad (16c)$$

$$\Psi_7 = (h_7 - h_0) - T_0(s_7 - s_0) \quad (16d)$$

$$\Psi_8 = (h_8 - h_0) - T_0(s_8 - s_0) \quad (16e)$$

$$\dot{E}x_7 = \dot{m}_{air} \times \Psi_7 \quad (16f)$$

$$\dot{E}x_8 = \dot{m}_{air} \times \Psi_8 \quad (16g)$$

$$\dot{E}x_{dest.evap} = \dot{m}_{ref} \times (\Psi_4 - \Psi_1) + \dot{m}_{air} \times (\Psi_7 - \Psi_8) \quad (16h)$$

$$\eta_{evap} = \frac{\dot{m}_{air} \Psi_8 + \dot{m}_{ref} \Psi_1}{\dot{m}_{air} \Psi_7 + \dot{m}_{ref} \Psi_4} \quad (16i)$$

Overall Exergy Efficiency of the refrigeration system:

$$\eta_r = \frac{\dot{E}x_{in.evap} - \dot{E}x_{out.evap}}{\dot{W}_{comp}} \quad (17)$$

Total Exergy Destruction:

$$\dot{E}x_{dest.evap} = \dot{E}x_{dest.comp} + \dot{E}x_{dest.pan} + \quad (18)$$

$$\dot{E}x_{dest.con} + \dot{E}x_{dest.cap} + \dot{E}x_{dest.evap}$$

### 3. RESULTS AND DISCUSSIONS

Thermodynamic properties of R410A were determined using the CoolPack software program. Enthalpy pressure and temperature values with and without panel system and the other points on Figure 1 and 2 were determined by using this software program. The calculated results of exergy analysis for Adana province for the system with and

without panel are given in Table 1 and 2, are found from the temperature and pressure values respectively. The other enthalpy and entropy values with the help of the lnP-h diagram of the R410A.

**Table 1.** Exergy analysis results of the system with panel

Province	State No	Description	Fluid	Phase	Temperature (°C)	Pressure (kPa)	Enthalpy (kJ/kg)	Entropy (kJ/kgK)	Mass Flow Rate (kg/s)	Specific Exergy (kJ/kg)	Exergy Rate (kW)
ADANA	0	-	Air	Dead state	36.8	101.05	-	-	-	0	0
	0	-	Ref. R410A	Dead state	36.8	101.05	465.56	2.189	-	0	0
	1	Evaporator outlet/ Compressor inlet	Ref. R410A	Super-heated vapor	34.6	1069.1	451.05	1.885	0.059	79.73	4.705
	2	Compressor outlet /Condenser inlet	Ref. R410A	Super-heated vapor	100.7	3160.1	491.36	1.901	0.059	114.99	6.786
	3	Condenser outlet/ Capillary tube inlet	Ref. R410A	Liquid	26.8	3160.1	244.75	1.153	0.059	100.14	5.909
	4	Capillary tube outlet/ Evaporator inlet	Ref. R410A	Mixture	9.5	3160.1	244.75	1.158	0.059	98.59	5.818
	5	Condenser inlet	Air	Gas	36.8	101.05	465.56	2.189	1.993	0	0
	6	Condenser outlet	Air	Gas	44.6	101.05	472.09	2.21	1.993	0.2546	0.507
	7	Evaporator inlet	Air	Gas	24.6	101.05	455.49	2.156	0.543	0.1534	0.083
	8	Evaporator outlet	Air	Gas	2.3	101.05	437.62	2.093	0.543	1.801	0.987
9	Solar panel outlet / Condenser inlet	Ref. R410A	Super-heated vapor	115.7	3160.1	508.3	1.946	0.059	118.02	6.964	

**Table 2.** Exergy analysis results of the system without panel

Province	State No	Description	Fluid	Phase	Temperature (°C)	Pressure (kPa)	Enthalpy (kJ/kg)	Entropy (kJ/kgK)	Mass Flow Rate (kg/s)	Specific Exergy (kJ/kg)	Exergy Rate (kW)
ADANA	0	-	Air	Dead state	36.8	101.05	-	-	-	0	0
	0	-	Ref. R410A	Dead state	36.8	101.05	465.56	2.189	-	0	0
	1	Evaporator outlet/ Compressor inlet	Ref. R410A	Super-heated vapor	34.6	1069.1	437.37	1.839	0.059	80.15	4.73
	2	Compressor outlet/ Condenser inlet	Ref. R410A	Super-heated vapor	100.7	3160.1	474.4	1.855	0.059	112.34	6.63
	3	Condenser outlet/Capillary tube inlet	Ref. R410A	Liquid	26.8	3160.1	274.16	1.246	0.059	100.74	5.95
	4	Capillary tube outlet/Evaporator inlet	Ref. R410A	Mixture	9.5	3160.1	274.16	1.263	0.059	95.49	5.64
	5	Condenser inlet	Air	Gas	36.8	101.05	465.56	2.189	1.993	0	0
	6	Condenser outlet	Air	Gas	43.9	101.05	470.55	2.205	1.993	0.0332	0.0662
	7	Evaporator inlet	Air	Gas	24.6	101.05	455.51	2.156	0.543	0.1734	0.0942
	8	Evaporator outlet	Air	Gas	2.3	101.05	441.27	2.107	0.543	1.1136	0.605

All calculations and results by using mass, energy, and exergy equations are compared for the systems with the panel and without the panel. Figure 4 shows the variation of compressor work and COP values for both with the panel and without panel systems. It is clearly seen that actual compressor work increases to 2.38 kW from 2.19 kW when the panel is used (with panel system) whereas COP value of with panel system will increase from 4.41 to 5.12. It can be seen that panel usage increases system COP by 16%.

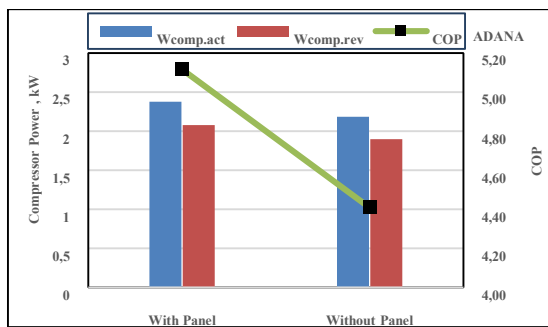

Figure 4. Variation of compressor work and COP

The main components of both systems in terms of exergy destruction rates are represented in Figure 5. The figure demonstrates that the degree of exergy destruction increased through the condenser and compressor for with panel system, but the rate of exergy destruction decreases through the evaporator and capillary tube. The maximum exergy destruction occurred in the condenser for with panel system as 1.55 kW. The minimum exergy destruction (0.091 kW) occurred in the capillary tube for with panel system.

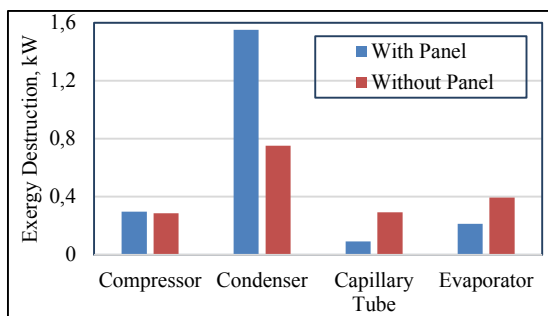

Figure 5. Variation of exergy destruction of system components

Figure 6 shows the exergy efficiency value of the components of the system. While exergy efficiency value in the compressor decreases for with panel system, but that value increases for the rest of the system components. The maximum exergy efficiency is seen to take place through the capillary tube, with a value of 98.5%. The other components of with panel system such as the evaporator, compressor, and condenser were shown to have an exergy efficiency of 96.3%, 81.5% and 48.1%, respectively. The highest efficiency increase was observed in the condenser by 25% when the solar panel is used.

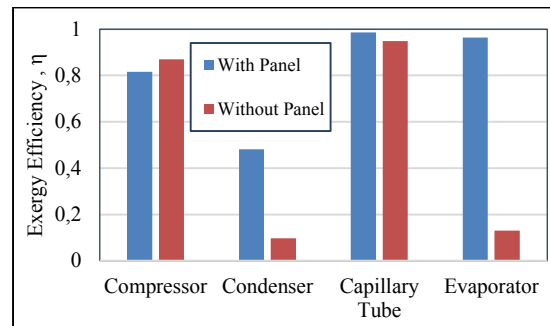

Figure 6. Variation of exergy efficiency of system components

The effect of panel usage on overall exergy efficiency for the air-conditioning system and the value of exergy destruction, are illustrated in Figure 7. As seen from this figure, the total exergy destruction and overall exergy efficiency values in both systems increase by using the panel. Total exergy destruction value increases from 1.73 kW to 2.34 kW and overall exergy efficiency values also increase from %65 to %84.4 by using the panel.

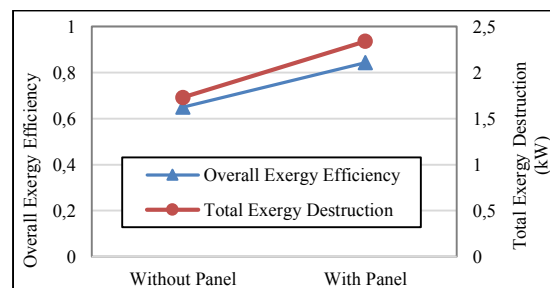

Figure 7. Variation of exergy efficiency and exergy destruction by panel usage



#### 4. CONCLUSIONS

Energy and exergy analyses of hybrid air conditioning system with and without panel usage and its components have been evaluated. The purpose of this work is to display the exergy destructions in air conditioning system when the panel is used. The results can be summarized as follows:

- Actual compressor work increases to 2.38 kW from 2.19 kW when the panel is used (with panel system) whereas COP value of with panel system will increase from 4.41 to 5.12. Panel usage increases system COP by 16%,
- Exergy destruction rate increases through the condenser and compressor, but decreases through the evaporator and capillary tube for with panel system,
- Exergy efficiency value in the compressor decreases, that value increases for the rest of the system components for with panel system,
- Total exergy destruction and overall exergy efficiency values increase by using the panel.

#### 5. ACKNOWLEDGEMENTS

The authors would like to thank the office of Scientific Research Projects of Cukurova University for funding this project under Contract no. FBA-2017-8809.

Nomenclature	
$COP$	coefficient of performance
$\dot{E}$	exergy rate (kW)
$\dot{E}x$	energy rate (kW)
$g$	gravitational acceleration ( $ms^{-2}$ )
$h$	enthalpy ( $kJkg^{-1}$ )
$\dot{m}$	mass flow rate ( $kgs^{-1}$ )
$\dot{Q}$	heat transfer rate (kW)
$s$	entropy ( $kJkg^{-1}K^{-1}$ )
$T$	temperature ( $^{\circ}C$ or $K$ )
$v$	velocity ( $ms^{-1}$ )
$\dot{W}$	work (kW)
$z$	altitude (m)
Greek Letter	
$\eta$	exergy efficiency

$\psi$	flow (specific) exergy ( $kJkg^{-1}$ )
Subscripts	
0	reference (dead) state
a	air
act	actual
atm	atmospheric
cap	capillary tube
comp	compressor
cond	condenser
dest	destruction
elec	electric
evap	evaporator
in	incoming
ind	indoor
out	outgoing
pan	panel
R	refrigeration system
ref	refrigerant
rev	reversible

#### 6. REFERENCES

1. Sevinç, K., Güngör, A., 2012. Güneş Enerjisi Kaynaklı Soğutma Sistemleri ve Bu Alandaki Yeni Uygulamalar, Mühendis ve Makina, 53-635, 59-70.
2. IEA, 2014. International Energy Agency. Emissions Reduction Through Upgrade of Coal-fired Power Plants, <https://www.iea.org>.
3. IRENA, 2016. International Renewable Energy Agency. Renewable Energy Benefits: Measuring the Economics, <http://www.irena.org>.
4. JRC, 2015. Joint Research Centre, Trends in global CO<sub>2</sub> emissions, [edgar.jrc.ec.europa.eu](http://edgar.jrc.ec.europa.eu).
5. Zheng, C.W., Li, C.Y., Pan, J., Liu, M.Y., Xia, L.L., 2016. An Overview of Global Ocean Wind Energy Resource Evaluations, Renewable and Sustainable Energy Reviews, 53, 1240-1251.
6. Ozbek, A., 2016. Exergy Characteristics of a Ceiling-type Residential Air Conditioning System Operating Under Different Climatic Conditions, Journal of Mechanical Science and Technology, 30-11, 5247-5255.
7. Ozbek, A., 2016. Energy and Exergy Analysis of a Ceiling-type Air Conditioning System

- Operating with Different Refrigerants, Journal of Engineering Research. 4-3, 144-162.
8. Vakiloroyaya, V., Ha, Q.P., Skibniewski, M., 2013. Modeling and Experimental Validation of a Solar Assisted Direct Expansion Air Conditioning System, Energy and Buildings, 66, 524-536.
  9. Paradeshi, L., Srinivas, M., Jayaraj, S., 2016. Parametric Studies of a Simple Direct Expansion Solar Assisted Heat Pump Operating in a Hot and Humid Environment, Energy Procedia 90, 635–644.
  10. Simsek, E., Karacayli, I., 2016. Güneş Panelinin Soğutma Modunda Çalışan Split Klima Sistemlerine Olan Etkilerinin Sayısal Olarak İncelenmesi, 1<sup>st</sup> International Conference on Engineering Technology and Applied Sciences, at Afyon Kocatepe University, Turkey.